

Chapter 4:

Spanning Tree Design Guidelines for Cisco NX-OS Software and Virtual PortChannels

Contents

Fundamental Spanning-Tree Concepts	3
MST Compared to Rapid PVST+	3
MST Concepts	4
Instances	5
Regions	5
MST Configuration Best Practices	8
VLAN Ranges in Cisco NX-OS Software	9
VLAN Ranges and MST Regions	9
Special Considerations for Spanning Tree with vPCs	10
How Spanning Tree Works in a vPC Deployment	10
Spanning-Tree Port Roles in Sample vPC Topologies	11
Type-1 Misconfiguration: Global and Interface Specific	13
Rapid PVST+ and vPC Best Practices	15
MST and vPC Best Practices	15
EtherChannel Misconfiguration Guard	15
Pathcost Method Long	17
Scaling Considerations	17
Logical Interfaces or BPDU States	17
Spanning-Tree Scalability with vPC Compared to Non-vPC Designs	18
Summary Checklist for Spanning Tree in a vPC Deployment	19

Fundamental Spanning-Tree Concepts

The first important choice to make in the design of a data center network is the spanning-tree choice. It is beyond the scope of this document to describe the spanning-tree algorithms in detail. At the time of this writing, the choice is between these two algorithms:

- Rapid Per-VLAN Spanning Tree Plus (PVST+): Information about Rapid PVST+ is available at http://www.cisco.com/en/US/partner/docs/switches/datacenter/sw/4_1/nx-os/layer2/configuration/guide/l2_pvrstconfig.html.
- Multiple Spanning Tree (MST): Information about MST is available at http://www.cisco.com/en/US/partner/docs/switches/datacenter/sw/4_1/nx-os/layer2/configuration/guide/l2_mstpconfig.html.

This document does not discuss Rapid PVST+ in detail because this protocol is already well known in the industry.

MST is discussed in detail here for the following reasons:

- With virtual PortChannel (vPC) deployments, VLAN load balancing is achieved automatically with no need to change spanning-tree priorities. Spanning-tree VLAN load balancing is much easier in Rapid PVST+ than it is in MST. With vPC topologies, this advantage is not applicable.
- MST scales better than Rapid PVST+ because the switch generates only one Bridge Protocol Data Unit (BPDU), which summarizes all the necessary information for the specific instance. With the increase in size of the Layer 2 domain, MST may become of greater interest because of its greater scalability and its capability to maintain a regional topology.

MST Compared to Rapid PVST+

MST allows you to assign two or more VLANs to a spanning-tree instance. MST is not the default spanning-tree mode; Rapid PVST+ is the default mode on Cisco® switches.

MST instances with the same name, revision number, and VLAN-to-instance mapping combine to form an MST region. The MST region appears as a single bridge to spanning-tree configurations outside the region.

The advantages of MST over Rapid PVST+ are as follows:

- MST is an IEEE standard.
- MST is more resource efficient. In particular, the number of BPDUs transmitted by MST does not depend on the number of VLANs, as Rapid PVST+ does.
- MST decouples the creation of VLANs from the definition for forwarding the topology.
- MST simplifies the deployment of stretched Layer 2 networks, because of its ability to define regions.

For all these reasons, it is advisable for many deployments to migrate to an MST-based topology.

Table 1 summarizes the differences between MST and Rapid PVST+.

Table 1. MST Compared to Rapid PVST+

	MST	Rapid PVST+
Number of instances	Typically 2 are enough	1 per VLAN
Scalability	Much greater than Rapid PVST+ (see limits)	
Interoperability with multichassis EtherChannels with vPC ports	Yes, but make sure that the MST region definition matches for primary and secondary vPC peers	Yes

	MST	Rapid PVST+
Separation between VLAN creation and topology definition	Yes	No
Ease of implementation of per-VLAN load balancing in spanning-tree topologies	Requires the definition of 2 instances and of the VLAN-to-instance mapping (In vPC deployments, VLAN load balancing is not needed any more.)	Easier to deploy for VLAN load balancing in classic spanning-tree designs (In vPC deployments, VLAN load balancing is not needed any more.)
Configuration complexity	More complex because of the need to maintain the region configuration across all switches in the Layer 2 domain; The network administrator needs to manually ensure that vPC peers are configured identically	Easier
Integration of large Layer 2 domains	Easier, due to the concept of regions	More convoluted because a single device becomes the root for the whole Layer 2 domain; no possibility to create Layer 2 regions

Rapid PVST+ offers slightly better flexibility for load balancing VLANs on a typically V-shape spanning-tree topology. With the adoption of vPC, this benefit is marginal because topologies are becoming intrinsically loop free, at which point the use of per-VLAN load balancing compared to per-instance load balancing is irrelevant (with vPC, all links are forwarding in any case).

MST Concepts

With IEEE 802.1s, you can create an instance, which means a number, to represent the topology, and you can map VLANs to this instance (Figure 1).

Figure 1. Traditional MST Design with Instance Load Balancing

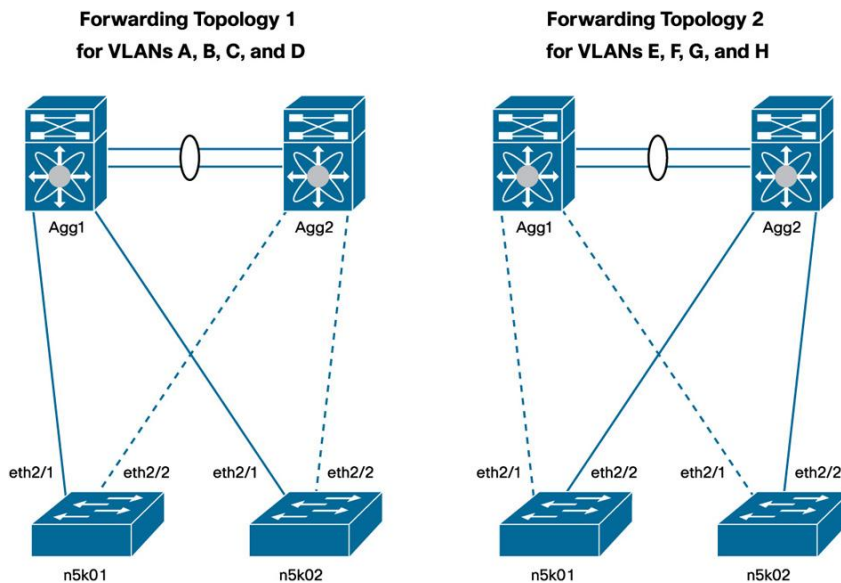

Figure 1 shows the topology according to IEEE 802.1s, or MST. The instance that represents the topology at the left is MST 1. VLAN A, B, C, and D are mapped to MST 1. At the right of the figure you can see the forwarding topology for MST 2.

If you do show spanning-tree VLAN A from the access layer, you see that the root bridge is Agg1. If you type the same command for VLAN E on the same switch, you see that the root bridge is Agg2. This difference occurs because VLAN A and VLAN E are mapped to two different instances.

The main difference between MST and Rapid PVST+ is that in Rapid PVST+, whenever you create a VLAN, an instance (topology) is automatically created, and mapping is not required. MST makes an abstraction between the topology and the VLANs that are carried over that topology (instance).

Instances

Instances are created with a simple statement:

```
instance 1 vlan 1-1000
```

This configuration maps VLANs 1 through 1000 to instance 1. Whether or not VLANs 1, 2, 3, etc. exist is irrelevant. After this topology is created, the VLANs can be created and assigned to trunks, but they do not have to be. The switches maintain the topology for instance 1 regardless.

This configuration maps VLANs 1 through 500 to instance 1, and VLANs 501 through 1000 to instance 2:

```
instance 1 vlan 1-500
instance 2 vlan 501-1000
```

The shape of the topology for instance 1 and for instance 2 does not depend on whether the VLANs are trunked. It strictly depends on the priority definition for that instance.

For example, you can create the topology shown in Figure 1 by using the following configuration:

```
nexus7k01(config)#spanning-tree mst 1 root primary
nexus7k01(config)#spanning-tree mst 2 root secondary

nexus7k02(config)#spanning-tree mst 1 root primary
nexus7k02(config)#spanning-tree mst 2 root secondary
```

MST uses a special instance to help ensure communication between regions: instance 0. You do not have to worry about instance 0, except that you may want to decide which device should be the root for instance 0 in a multi-region topology.

Regions

As previously mentioned, the main enhancement introduced by MST is that several VLANs can be mapped to a single spanning-tree instance. As many instances can be defined as there are forwarding topologies (typically, there are two forwarding topologies).

A region is a configuration consisting of the list of instances and associated VLAN mappings (and, incidentally, also a revision number). No automatic propagation of this mapping exists; it is the administrator's job to make sure that the configuration is properly maintained across all the switches that are part of the same region.

For example, the following configuration fully defines a region:

```
spanning-tree mst configuration
name dc1
revision 1
instance 1 vlan 1-1000
```

In this region, only one instance is defined, instance 1, and VLANs from 1 to 1000 are associated with this spanning-tree topology.

Another switch connected to the region previously defined can be configured as follows:

```
spanning-tree mst configuration
name dc1
revision 1
instance 1 VLAN 1-500
instance 2 VLAN 501-1000
```

This configuration defines a different region than the one that had only one instance configured. The communication between the two MST regions uses instance 0 and the ports interconnecting the two switches are boundary ports.

Note: For switches to belong to different regions, it is enough that the revision number be different.

This particular aspect of MST may appear intimidating because it is possible to have different regions within the same Layer 2 topology as the result of a change in the VLAN mapping in one of the switches. In reality, while changing the VLAN mapping causes some minor disruption, the forwarding topology always converges to help ensure connectivity between hosts, as Figure 2 illustrates.

Figure 2. In MST Different Region Mappings Define Different Regions

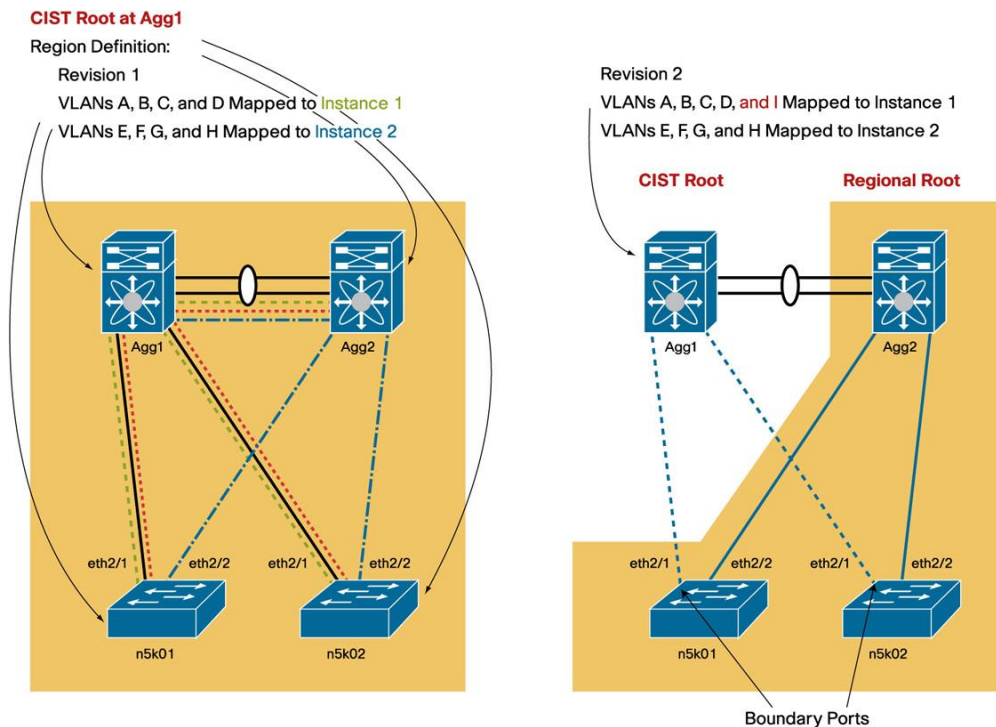

In Figure 2, Agg1 is configured with, for example, VLAN A, B, C, and D belonging to topology 1, and E, F, G, and H mapped to instance 2 (topology 2). The forwarding topology of each instance is color coded in the figure: the dashed line represents instance 1, and the dash-dot line represents instance 2.

If Agg1 is configured with VLANs A, B, C, D, and I as part of topology 1, then the two switches appear to belong to separate regions, as the right portion of the figure illustrates. This configuration will make the Cisco Nexus® 5000 Series Switches n5k01 and n5k02 elect Agg2 as their regional root, so the ports connecting to it are forwarding for both instances 1 and 2. The ports connecting to Agg1 become boundary ports, and they are blocking on both n5k01 and n5k02. This approach is different from the original topology but still provides connectivity.

Now the administrator configures Agg2 for the new topology (Figure 3).

Figure 3. Migrating an Existing MST Topology in order to Define a Unique Region

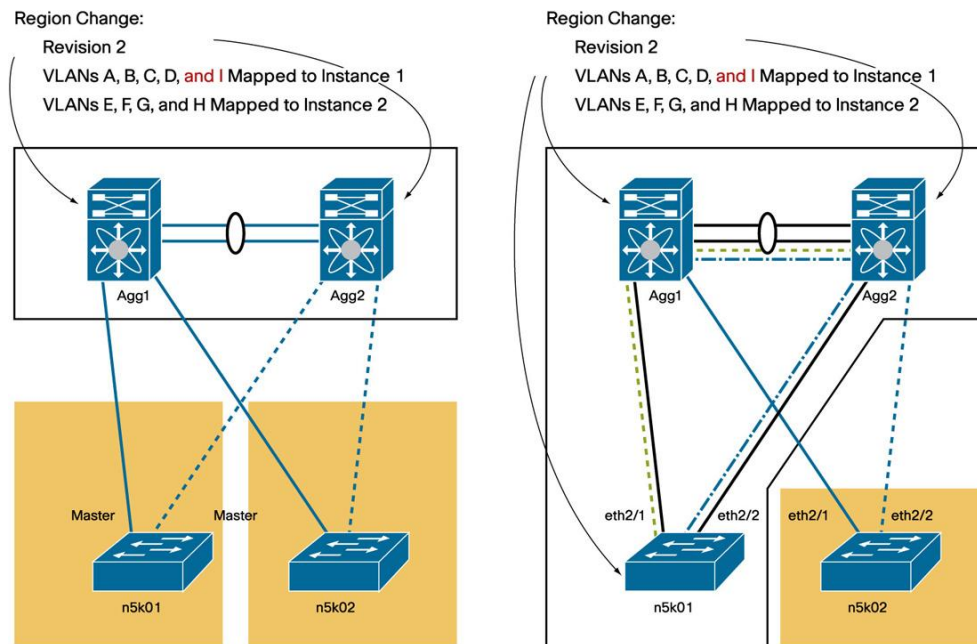

The left part of the figure shows that as a result of the configuration on Agg2, Agg1 and Agg2 now are part of the same region, while n5k01 and n5k02 belong to the original region, which is split because n5k01 and n5k02 are not directly connected. As a result, all VLANs are forwarding on the master port on n5k01 and n5k02. Quoting IEEE, "A Master Port provides connectivity from the Region to a CIST Root that lies outside the region." This topology is not the final one, but it still provides network connectivity to the end host.

The administrator now configures n5k01, and as a result n5k01 joins the region, and as a result instance 1 is forwarding on eth2/1 on n5k01 and blocking on eth2/2; n5k02 is still in a different region, so all VLANs are forwarding on eth2/1, the master port.

Finally, n5k02 is configured, and it joins the region, resulting in exactly the same topology as at the beginning of the configuration change (Figure 4).

Figure 4. Final MST Topology After All Switches Have Been Migrated to the Same Region Definition

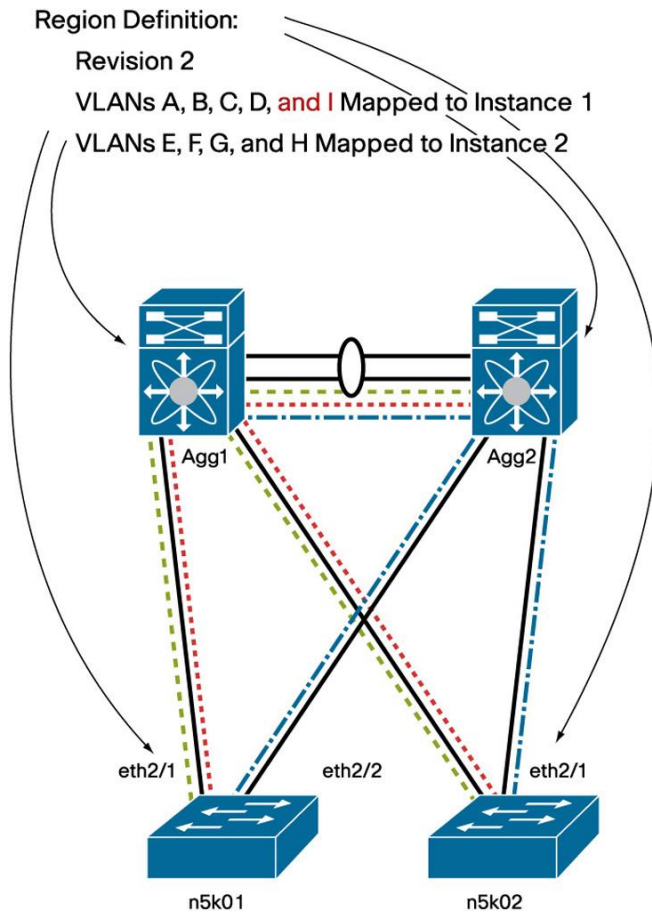

Although a temporary topology flapping as a result of region definition is minimally disruptive, it can also be avoided altogether by defining the regions at the deployment phase for all VLANs 1 through 4094 (0 and 4095 are reserved). This definition exerts no load on the system and does not require definition of all the VLANs; VLANs can be created and assigned to trunks later with no disruption.

MST Configuration Best Practices

MST configuration requires the following steps:

- Define a region configuration to be copied to all the switches that are part of the Layer 2 topology.
- As part of the region configuration, decide to which instance all VLANs 1 through 4096 belong. In typical deployments, you would need to define two instances (in a vPC deployment, you need to define only one).
- Copy the region configuration on all the switches as needed. It is very unlikely that you will ever have to modify this configuration after you have defined it.
- Define primary and secondary root switches for the instances that you have defined, as well as for instance 0. Typically, the primary root for MST 0 and MST 1 is one aggregation switch, and the secondary root is the redundant aggregation switch.
- Preprovision all VLAN (1 through 4094) mappings and topologies and then create VLANs later as needed:
`spanning-tree mode mst`

```
spanning-tree mst configuration
  name dc1
  revision 1
  instance 1 vlan 1-4096

spanning-tree mst 0-1 root primary
```

VLAN Ranges in Cisco NX-OS Software

In its current implementation, the Cisco Nexus product family supports VLANs in the ranges 1 through 3967 and 4048 through 4093.

You can find the ranges of reserved VLANs by entering this command:

```
tc-nexus5k01# show vlan internal usage
```

VLAN	DESCRIPTION
-----	-----
3968-4031	Multicast
4032	Online diagnostics vlan1
4033	Online diagnostics vlan2
4034	Online diagnostics vlan3
4035	Online diagnostics vlan4
4036-4047	Reserved
4094	Reserved

Note: For more information, see http://www.cisco.com/en/US/partner/docs/switches/datacenter/sw/4_2/nx-os/layer2/configuration/guide/Cisco_Nexus_7000_Series_NX-OS_Layer_2_Switching_Configuration_Guide_Release_4.2_chapter3.html#con_1273370.

The Cisco Nexus 5000 Series hardware supports up to 512 VLANs whose numbers can be selected from the ranges listed here. Up to 32 of these VLANs can be used for VSAN purposes, in which case they are not available any more for regular IP traffic. In addition, some VLANs are used for internal communication. Thus, a combined total of 505 VLANs and VSANs can be configured by the user.

Even if the Cisco Nexus 5000 Series supports 505 VLANs, you can configure an MST region for the full range of more than 4000 VLANs previously listed.

VLAN Ranges and MST Regions

In the Cisco Catalyst® product family, the reserved VLAN range is different from the Cisco NX-OS VLAN range (for more information, see <http://www.cisco.com/en/US/docs/switches/lan/catalyst6500/ios/12.1E/native/configuration/guide/vlans.html>).

- VLANs 1002 through 1005 are reserved.
- In Cisco NX-OS, the MST instance mapping looks like this:

```
instance 1 vlan 1-3967,4048-4093
```
- In Cisco Catalyst products, the MST instance mapping looks like this:

```
instance 1 vlan 1-4094
```

If you have a Cisco Catalyst switch connected to a Cisco Nexus switch, you need to configure the MST regions on the Cisco Catalyst switches without the Cisco NX-OS reserved VLANs, so you have to copy the Cisco NX-OS instance mapping to the Cisco Catalyst switch configuration.

Special Considerations for Spanning Tree with vPCs

Even if the Cisco Nexus devices are configured for vPC, each device preserves its root or secondary root role or whichever priority it has as defined by the spanning-tree configuration.

The main difference between a vPC configuration and a non-vPC configuration is in the forwarding behavior of the vPC peer link and the BPDU forwarding behavior of vPC member ports only.

Non-vPC ports on a vPC-configured switch behave in the same way as on a regular switch, except that the vPC peer link is always forwarding, which may require a slightly different (but still valid) topology.

How Spanning Tree Works in a vPC Deployment

A vPC deployment has two main spanning-tree modifications that matter:

- vPC imposes the rule that the peer link should never be blocking because this link carries important traffic such as the Cisco Fabric Services over Ethernet (CFS over Ethernet) Protocol. The peer link is always forwarding.
- For vPC ports only, the operational primary switch generates and processes BPDUs. The operational secondary switch forwards BPDUs to the primary switch.

Figure 5 provides an example.

In this example, 5k01 and 5k02 are configured for vPC. Ports eth2/9 on both switches are vPC member ports, and ports eth2/10 are regular spanning-tree ports.

Switch 5k01 is the operational primary switch, but 5k02 is the root for VLAN 50 and is the operational secondary switch. On vPC ports 2/9, the spanning-tree behavior previously described applies. On regular ports 2/10, the regular spanning-tree behavior applies.

Because of vPC, the operational secondary switch cannot send BPDUs from port 2/9, nor it can process them; if a BPDU arrives on port 2/9, the secondary switch sends it to the primary switch. Also, the primary switch is the one that can generate BPDUs to the vPC ports.

So although 5k02 is the root for VLAN 50, only 5k01 is allowed to send the BPDUs from 5k02 to port 2/9.

Figure 5. Spanning-Tree Behavior with vPC

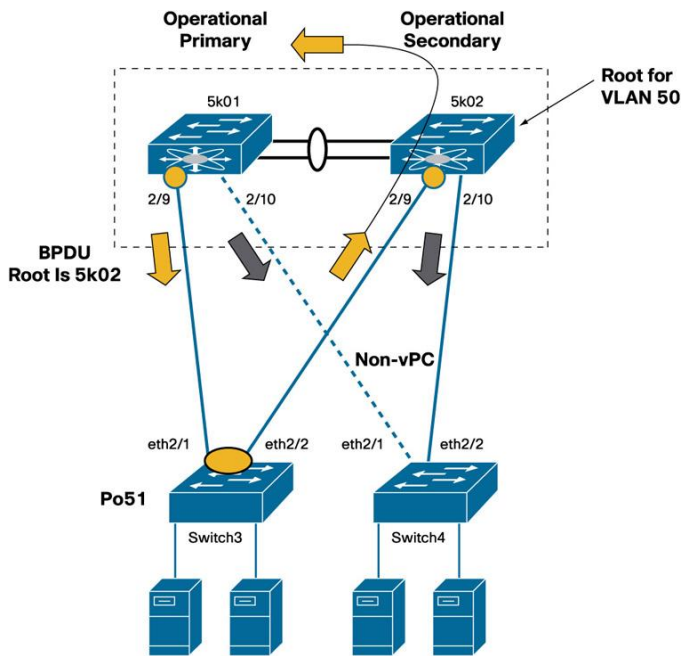

Switch 5k02 can send BPDUs on port 2/10 because this port is not part of a vPC.

Switch 5k01 will announce 5k02 BPDUs with the bridge ID of 5k02, so from the viewpoint of Switch3 the root can be reached through Po51, and the bridge ID of the root is that of 5k02. Switch3 receives the BPDUs from the root through port eth2/1 on Po51.

Spanning-Tree Port Roles in Sample vPC Topologies

This section provides some examples of forwarding topologies with various spanning-tree root and vPC primary and secondary switch placements. This topology is a dual-sided vPC deployment with vPC running on Cisco Nexus 7000 and 5000 Series Switches (Figure 6).

In this topology, 7k01 is the root, and the vPC operational secondary switch. As a result, the peer link to the operational primary switch is a designated port. The PortChannel to the access layer is a designated port on both 7k01 and 7k02 (since they appear as a single spanning-tree entity to the access switches, on vPC ports).

At the access layer, 5k01 is the operational primary switch, and 5k02 is the operational secondary switch. The peer link on 5k01 appears as a root port (because it connects to the operational primary switch), and PortChannel 51 is also a root port because it is the path to the root.

Note: Unlike a regular spanning-tree deployment, a vPC deployment can have two root ports.

Figure 6. Spanning-Tree Topology in a Double-Sided vPC Design with Mismatched vPC Primary and STP Root

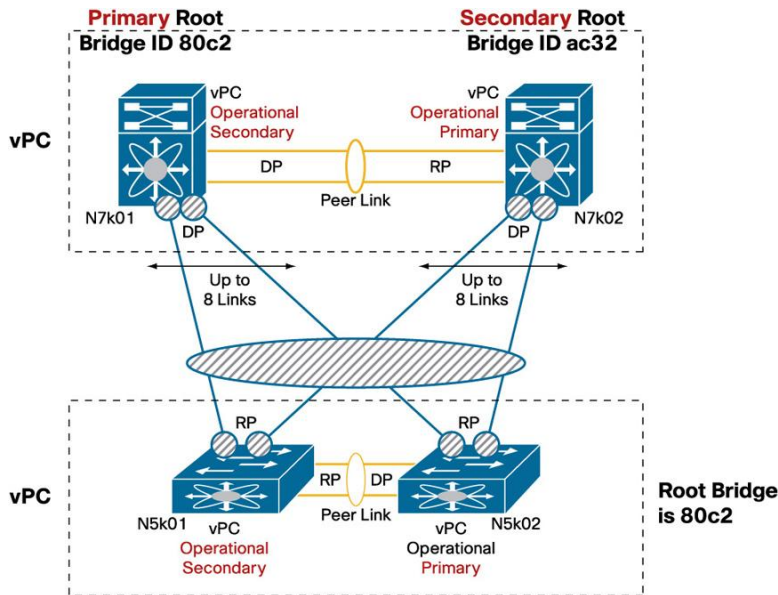

If you make 7k02 the root and 7k01 the secondary root, the topology changes as shown in Figure 7.

As Figure 7 shows, the peer link on 7k01 to 7k02 is now a root port, because 7k02 is the primary switch, and it is the root switch.

On the access layer, the Cisco Nexus 5000 Series Switch now sees ac32 as the root device.

Figure 7. Spanning-Tree Topology in a Double-Sided vPC Design with vPC Primary and STP Root on the Same Switch

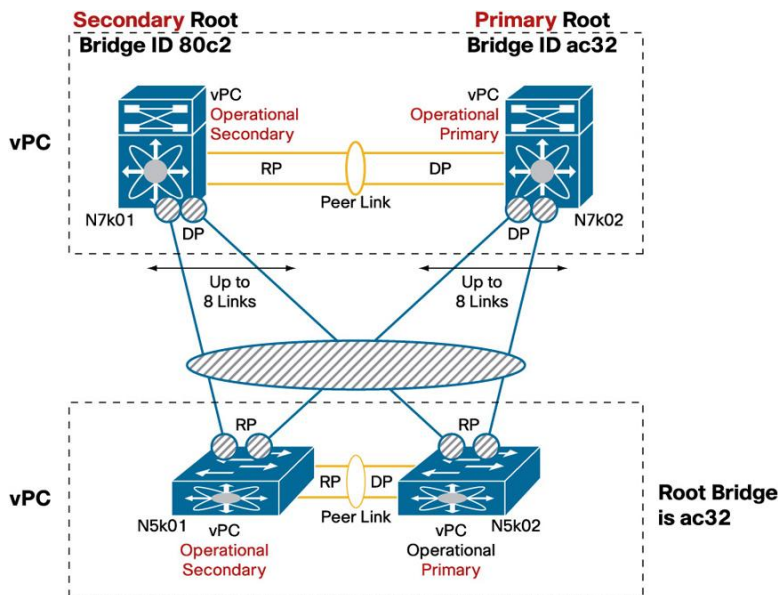

Type-1 Misconfiguration: Global and Interface Specific

In a vPC deployment, ports can form a vPC only if the consistency rules are met. There are two types of consistency rules: global rules and interface-specific rules.

- Global inconsistencies: A Type-1 global inconsistency prevents all vPCs from forming (but does not affect non-vPC ports).
- Interface-specific inconsistencies: Type-1 interface-specific inconsistencies affect only the interface itself.

Global inconsistencies are as follows (Figure 8):

```
tc-nexus5k01# show vpc consistency-parameters global
```

Legend:

Type 1: vPC will be suspended in case of mismatch

Name	Type	Local Value	Peer Value
QoS	1	([], [3], [], [], [], [])	([], [3], [], [], [], [])
Network QoS (MTU)	1	(9216, 2240, 0, 0, 0, 0)	(9216, 2240, 0, 0, 0, 0)
Network QoS (Pause)	1	(F, T, F, F, F, F)	(F, T, F, F, F, F)
Input Queuing (Bandwidth)	1	(50, 50, 0, 0, 0, 0)	(50, 50, 0, 0, 0, 0)
Input Queuing (Absolute Priority)	1	(F, F, F, F, F, F)	(F, F, F, F, F, F)
Output Queuing (Bandwidth)	1	(50, 50, 0, 0, 0, 0)	(50, 50, 0, 0, 0, 0)
Output Queuing (Absolute Priority)	1	(F, F, F, F, F, F)	(F, F, F, F, F, F)
STP Mode	1	Rapid-PVST	Rapid-PVST
STP Disabled	1	None	None
STP MST Region Name	1	dc1	dc1
STP MST Region Revision	1	3	3
STP MST Region Instance to VLAN Mapping	1		
STP Loopguard	1	Disabled	Disabled
STP Bridge Assurance	1	Enabled	Enabled
STP Port Type, Edge BPDUGuard	1	Normal, Disabled, Disabled	Normal, Disabled, Disabled
STP MST Simulate PVST	1	Enabled	Enabled
Allowed VLANs	-	1,10-14,21-24,30,50,60	1,10-14,21-24,30,50,60

Thus, it is advisable to preprovision VLAN mappings on MST as is usual in existing MST deployments.

Remember that vPC inconsistencies affect only vPC member ports, not the regular switch ports.

Figure 8. Type-1 Global Misconfiguration Example

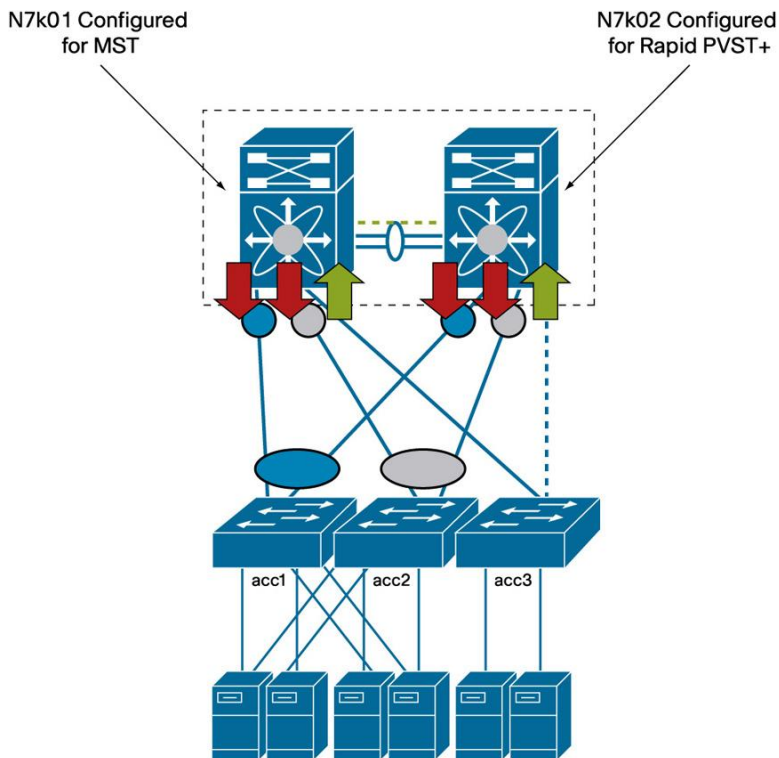

Interface-specific inconsistencies are as follows:

```
tc-nexus5k01# show vpc consistency-parameters interface po51
```

Legend:

Type 1: vPC will be suspended in case of mismatch

Name	Type	Local Value	Peer Value
STP Port Type	1	Default	Default
STP Port Guard	1	None	None
STP MST Simulate PVST	1	Default	Default
lag-id	1	[(7f9b, 0-23-4-ee-be-1, 8033, 0, 0), (7f9b, 0-23-4-ee-be-2, 8033, 0, 0)]	[(7f9b, 0-23-4-ee-be-1, 8033, 0, 0), (7f9b, 0-23-4-ee-be-2, 8033, 0, 0)]
mode	1	passive	passive
Speed	1	10 Gb/s	10 Gb/s
Duplex	1	full	full
Port Mode	1	trunk	trunk
Native Vlan	1	1	1

Shut Lan	1	No	No
Allowed VLANs	-	10-14, 21-24, 30, 50-51, 6	10-14, 21-24, 30, 50-51, 6

If any of these parameters differ between vPC peers, the vPC does not forward traffic.

Rapid PVST+ and vPC Best Practices

When configuring Rapid PVST+ with vPC, follow these best practices:

- Associate the root role on the aggregation layer as usual and it is preferred to match the vPC primary and secondary roles with root and secondary root. Remember that if a peer link fails, the vPC ports on the secondary switch are shut down, so make sure that the topology works regardless of which vPC peer is the operational secondary switch.
- Two options are available for non-vPC VLANs to avoid the scenario in which the switch virtual interface (SVIs) for non-vPC VLANs are shut down if the peer link fails. You can place the non-vPC VLANs on a backup link that is independent of and parallel to the vPC peer link. In this case, make sure to clear the peer link from the non-vPC VLANs. Alternatively, you can use the command **dual-active exclude interface-vlan** to help ensure that non-vPC SVIs stay available.

MST and vPC Best Practices

When configuring MST with vPC, you should follow the same best practices as for Rapid PVST+. In addition, you should follow these practices:

- Associate the root and secondary root role at the aggregation layer and it is preferred to match the vPC primary and secondary roles with root and secondary root.
- You do not need to use more than one instance for vPC VLANs.
- Make sure to configure regions during the deployment phase.
- If you make changes to the VLAN-to-instance mapping when vPC is already configured, remember to make changes on both the primary and secondary vPC peers to avoid a Type-1 global inconsistency.
- Use the **dual-active exclude interface-vlan** command to avoid isolating non-vPC VLAN traffic when the peer link is lost.

EtherChannel Misconfiguration Guard

A dispute mechanism was introduced for the Cisco Catalyst 6500 Series Switches in Cisco IOS[®] Software Release 12.2(18)SXF for MST and in Cisco IOS Software Release 12.2(33)SXI for Rapid-PVST+, prior to the introduction of vPC to deal with a scenario such as the one described here.

If upstream switch1 and switch2 are not configured for vPC, but the downstream access switches (switch3 and switch 4) are configured with PortChannel mode on, then broadcast frames will loop back, causing duplicates as depicted in Figure 9. The misconfiguration guard takes down the PortChannel on the downstream switch to avoid this scenario.

The misconfiguration guard detects this scenario by seeing BPDUs with different Bridge IDs that originate on both PortChannel links.

Figure 9. Etherchannel Misconfiguration Guard

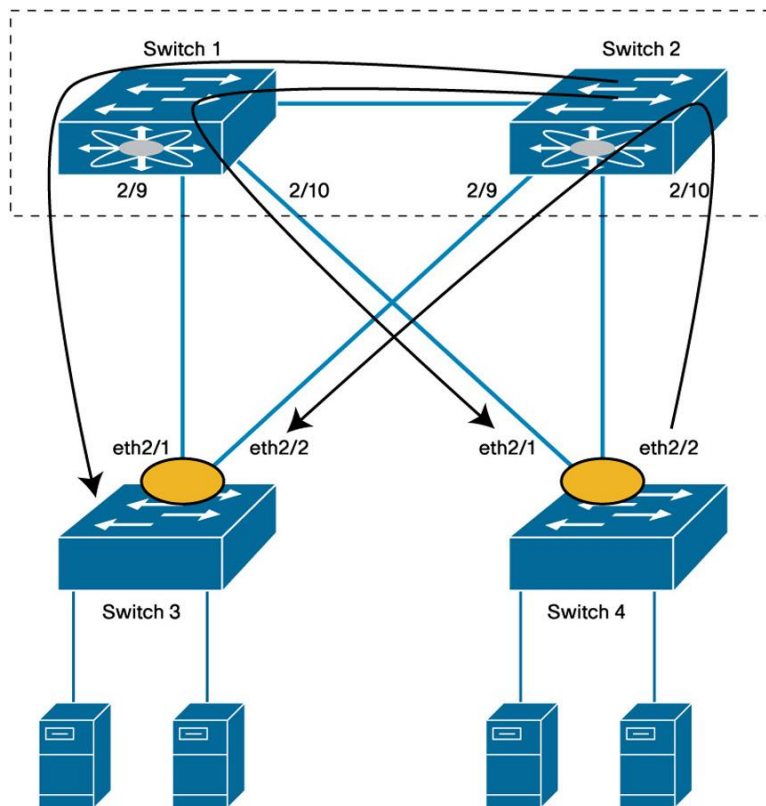

When Switch1 and Switch2 are configured as a vPC system, Cisco Catalyst Switch3 and Switch4 see the BPDUs coming only from one port: the port connecting to the primary vPC switch. Alternatively, when the vPC peer switches are disconnected (dual-active scenario), both start generating BPDUs, at which point EtherChannel misconfiguration guard intervenes to shut down the links connecting to the Cisco Nexus switches because in this case Switch1 and Switch2 would generate BPDUs with different Bridge IDs.

Because of this EtherChannel misconfiguration guard on the Cisco Catalyst platforms used to interfere with the vPC dual-active failure scenarios whereby two Cisco Nexus switches that were previously forming a vPC system are losing connectivity on both the peer link and the peer keepalive link. Starting from Cisco NX-OS 4.2 this problem doesn't exist any more.

Note: The misconfiguration guard is not really required in the case of a vPC dual-active failure, because there is no remaining connectivity between Switch1 and Switch2; thus, this protection does not need to be implemented.

This protection is also unnecessary when the vPC peer keepalive link is up, because vPC implements a recovery mechanism that shuts down vPC member ports on the secondary vPC peer.

If running a Cisco NX-OS release prior to 4.2 and to reduce the effect on production traffic, disable the EtherChannel misconfiguration protection (or dispute mechanism) as shown here on the access-layer switches if they run Cisco Catalyst switches and Cisco IOS Software (you do not need to do this on Cisco NX-OS devices):

```
no spanning-tree etherchannel guard misconfig
```

Pathcost Method Long

If you are not using spanning-tree **pathcost method long**, the cost of most links in a data center is almost identical regardless of the available bandwidth along a given path:

- 1-Gbps link = 4
- 2- Gbps links = 3
- 3- Gbps links = 3
- 4- Gbps links = 3

Considering that spanning tree was designed before the availability of 10 Gigabit Ethernet or even Gigabit Ethernet, the default spanning-tree reference cost for a link is inadequate, as most links with 10 Gigabit Ethernet bandwidth or bandwidth with multiples of 10 Gigabit Ethernet will appear to have the same cost.

With spanning-tree **pathcost method long** enabled, spanning tree calculates the best forwarding path according to the link bandwidth to the root and not based on hop count. With this command, the cost of links is as follows (these numbers are weights so they don't have a specific measurement unit):

- One Gigabit Ethernet link = 20,000
- Two Gigabit Ethernet links = 10,000
- Three Gigabit Ethernet links = 6660
- Four Gigabit Ethernet links = 5000

The cost with 10 Gigabit Ethernet links is as follows:

- One 10 Gigabit Ethernet link = 2,000
- Two 10 Gigabit Ethernet links = 1,000

Scaling Considerations

Design scalability is based on various factors, including:

- Number of PortChannels supported (discussed in Chapter 3 of this guide)
- Number of VLANs supported by a switch
- Logical interface count (also called bridge state count) for the control plane of a given switch
- Oversubscription rate

Logical Interfaces or BPDU States

A logical port is the sum of the number of physical ports times the number of VLANs on each port. This value is what produces load on the CPU because each port that includes a VLAN has to generate and process BPDUs.

The more VLANs on the trunks, the higher the load on the CPU. This load is one of the reasons you should clear trunks from unnecessary VLANs.

The upper limit of logical ports that a switch can support depends on the spanning-tree algorithm. With Rapid PVST+, each VLAN is a separate instance of the spanning-tree algorithm, which means that Rapid PVST+ can support fewer VLANs than MST.

Scalability limits are documented on the Cisco.com online page in two formats:

- Logical interfaces
- Bridge states

The Cisco Nexus 5000 Series Switch and 2000 Series Fabric Extenders use the concept of BPDU states to express scalability limits instead of using logical interfaces. As already mentioned, the BPDU state count is different from the logical interface count. Also remember that host ports configured for BPDU filtering do not have any BPDU state except at link up, so the limits expressed in terms of BPDU state are an indication of how many switch-to-switch trunks can be configured.

In the case of Rapid PVST+, the bridge state count maps exactly to the logical interface count, but in the case of MST, the bridge state scalability really refers to the number of instances (and not VLANs) times the number of ports.

For some of the scalability values, see the following:

- Cisco Catalyst 6500 Series:
http://www.cisco.com/en/US/partner/docs/switches/lan/catalyst6500/ios/12.2SX/release/notes/ol_14271.html#wp26366.
- Cisco Nexus 7000 Series: http://www.cisco.com/en/US/partner/docs/switches/datacenter/sw/4_1/nx-os/layer2/configuration/guide/l2_limitsapp.html.
- Cisco Nexus 5000 and 2000 Series:
http://www.cisco.com/en/US/docs/switches/datacenter/nexus5000/sw/configuration/guide/cli_rel_4_0_1a/limits.html.

Spanning-Tree Scalability with vPC Compared to Non-vPC Designs

When vPC is used, only the primary vPC device processes BPDUs; the secondary device simply passes them over the peer link to the primary device. You should factor in this behavior when calculating the logical interfaces in a vPC deployment.

As a result, when calculating scalability for a vPC deployment, you should look at the total logical interfaces for a system composed of two vPC peer switches and compare the limits for a single device.

Using the processing power of the primary vPC device to handle both vPC peers yields the same scalability as having two separate switches with regular spanning-tree topologies because most links are PortChannels; each PortChannel counts as a single logical port regardless of the number of links it contains.

In addition, in these topologies spanning tree is not doing much because all links are forwarding and most failures are recovered by the PortChannel logic without any need for spanning-tree intervention (Figure 10).

In Figure 10, Agg1 and Agg2 are configured as part of the same vPC or virtual switching system (VSS).

To calculate the scalability, multiply the number of vPCs times the number of VLANs for each vPC and make sure that the result is below the maximum number of logical interfaces supported by one (and one only) of the aggregation switches.

For example, assuming 10 VLANs per vPC, the number of logical interfaces is $3 \times 10 = 30$.

Figure 10. Calculation of the Logical Interface in a vPC Design

Logical Interfaces Connected to the 2 Systems =
 Number of PortChannels x VLANs < Maximum for 1 Device

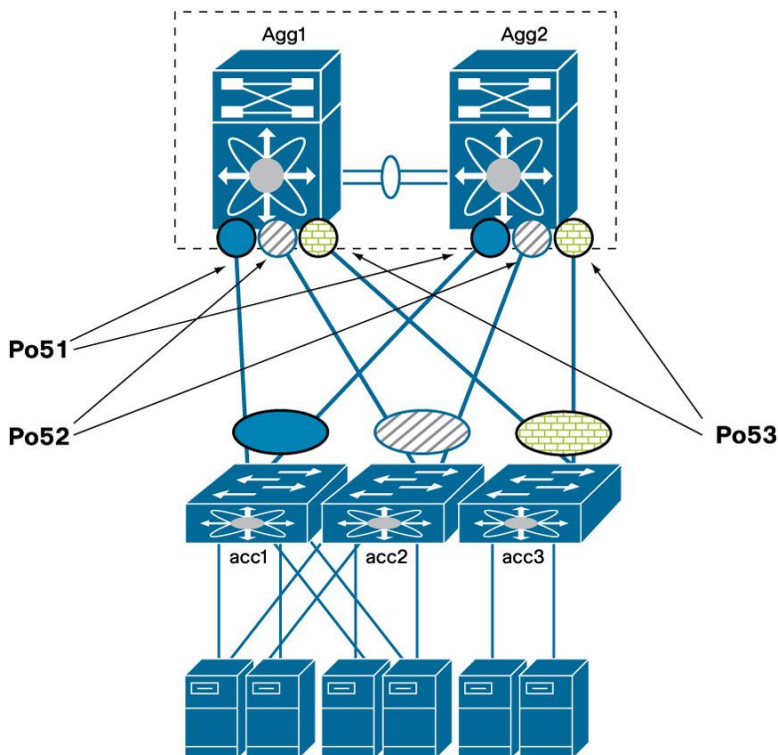

Summary Checklist for Spanning Tree in a vPC Deployment

The ideal configuration for a vPC deployment is summarized here:

- Choose the spanning-tree algorithm, keeping in mind that MST scales better, but that Rapid PVST+ is easier to deploy. Also you should not deploy MST unless you fully understand the region concept and Type-1 global misconfiguration.
- Verify the VLAN range that is used in the topology and make sure that all devices are configured for the VLAN range that is common to all platforms.
- Be mindful of non-vPC ports (orphaned ports) and consider the topology behavior for these ports and for the associated SVIs when the peer link is lost. Take advantage of the **dual-active exclude interface-vlan** command to avoid isolating non-vPC VLAN traffic when the peer link is lost.
- **Preprovision MST:** Make sure you understand the MST region concept and vPC Type-1 global misconfiguration. Create the region configuration for the deployment as well as all the VLAN mappings. VLAN creation can be performed after deployment with no disruption. Region modifications should be limited to deployment time to reduce the need for topology recalculations and to avoid Type-1 misconfiguration.
- On the aggregation layer, create a root or a secondary root device as usual. Design the network to match the primary and secondary roles with the spanning-tree primary and secondary switches
- Make sure **pathcost method long** is enabled.



Americas Headquarters
Cisco Systems, Inc.
San Jose, CA

Asia Pacific Headquarters
Cisco Systems (USA) Pte. Ltd.
Singapore

Europe Headquarters
Cisco Systems International BV Amsterdam,
The Netherlands

Cisco has more than 200 offices worldwide. Addresses, phone numbers, and fax numbers are listed on the Cisco Website at www.cisco.com/go/offices.

 Cisco and the Cisco logo are trademarks or registered trademarks of Cisco and/or its affiliates in the U.S. and other countries. To view a list of Cisco trademarks, go to this URL: www.cisco.com/go/trademarks. Third party trademarks mentioned are the property of their respective owners. The use of the word partner does not imply a partnership relationship between Cisco and any other company. (1110R)